

ASMPT enabling the
digital world



SIPLACE SX

Maximum flexibility for the intelligent factory

THE NEW GENERATION SIPLACE SX

EVEN THE BEST WAS NO LONGER GOOD ENOUGH FOR US

What happens when the most demanding electronics manufacturers get together with the most innovative developers? They go to work to make the best placement solution on the market even better. The new generation of the SIPLACE SX placement platform is now faster, more accurate and more flexible. It is also smart, open, learns quickly, adapts to any challenge, and makes your employees' lives easier.

With options such as Smart Pin Support, the OSC Package, the Clinching Tool and the exchange of complete feeder tables with AMR solutions, to name just a few, it also fits perfectly into ASMPT's modular, flexible and manufacturer-independent concept of the intelligent factory.

Get to know the new SIPLACE SX and learn what's possible in today's high-mix production environments – and no other machine can deliver.



Modular, flexible, open – attributes that perfectly describe our SIPLACE SX. Standard interfaces and a growing number of automation options make it the number one choice for your intelligent factory.

THE HEAD MAKES THE DIFFERENCE

THREE INNOVATIVE PLACEMENT HEADS DELIVER PERFORMANCE, FLEXIBILITY AND BALANCE.

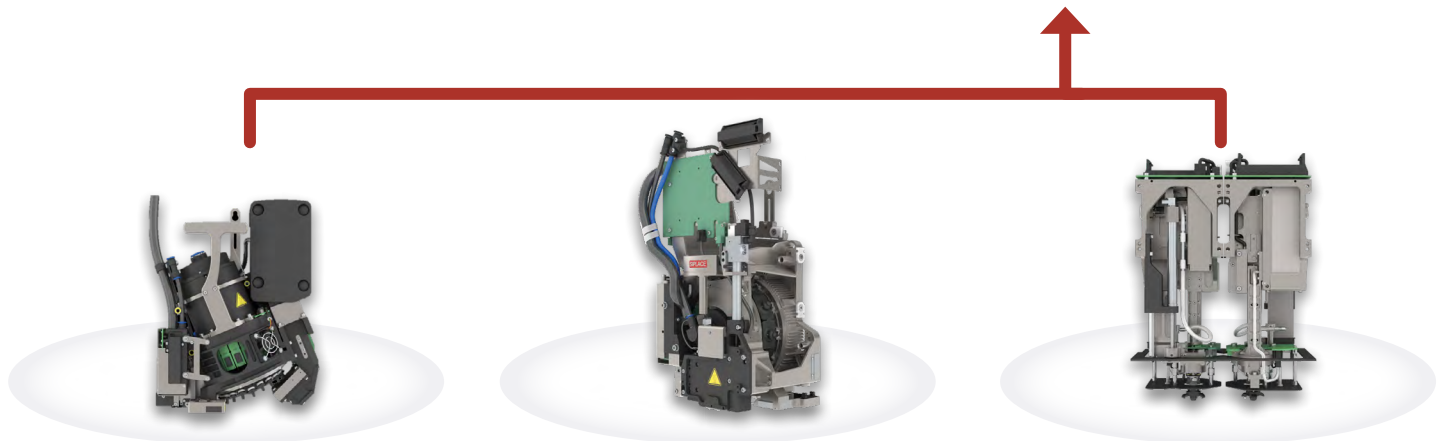

Placement Head CP20

- Expanded component spectrum: 0201 metric to 8.2 mm × 8.2 mm × 4 mm
- More placement precision: ±34 µm @ 3 sigma
- Extremely fast: Up to 43,250 cph
- Maximum reliability: New component camera with GigE interface for better images with higher resolution

Placement Head CPP

- Switches from pick-and-place to collect-and-place to mixed mode
- Component height: Up to 15.5 mm
- Component weight: Up to 20 g
- Automatic pin 1 detection
- LED Centering

Placement Head TWIN

- Component height: Up to 50 mm
- Component weight: Up to 300 g
- Snap-in detection
- Improved THT placement
- Placement force up to 100 N (TWIN VHF version)

THE SIPLACE SX PUTS YOU ON THE FAST TRACK



Scalable

Unique interchangeable gantries allow you to shift placement capacity to where it's needed

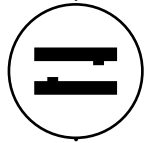

Total flexibility

Tapes, sticks, bowls, trays and many more feeder options in addition to flexible multi-track conveyors and PCB sizes of up to 1,525 mm by 560 mm

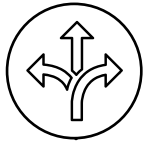

Fast

Up to 86,500 cph



Smart

Intelligent self-healing, self-learning and self-verification functions reduce operator assists to a new minimum

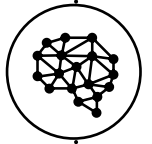

OSC Package

For very odd-shaped, large and/or heavy components and full THT capabilities

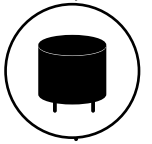

Ready for predictive maintenance

Sensors monitor the machine's behavior. SmartNozzles with RFID tag



Powerful software

Our superior programming, station software and workflow solutions ensure top performance and easy operation

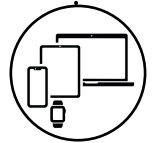

SMART WORKFLOWS

WORKS SOFTWARE SUITE

With the WORKS Software Suite, you get the most out of your SIPLACE SX production line and lay the foundation for your intelligent factory. It makes your employees' work easier in their respective areas, controls and optimizes the production flow, and calculates the component requirements during the assembly process. AMR fleet management applications and enterprise solutions such as MES and ERP software can be easily connected.

Open and standard-based interfaces such as IPC-HERMES-9852 and IPC-CFX ensure consistent M2M and M2H communication.

More about the SIPLACE SX



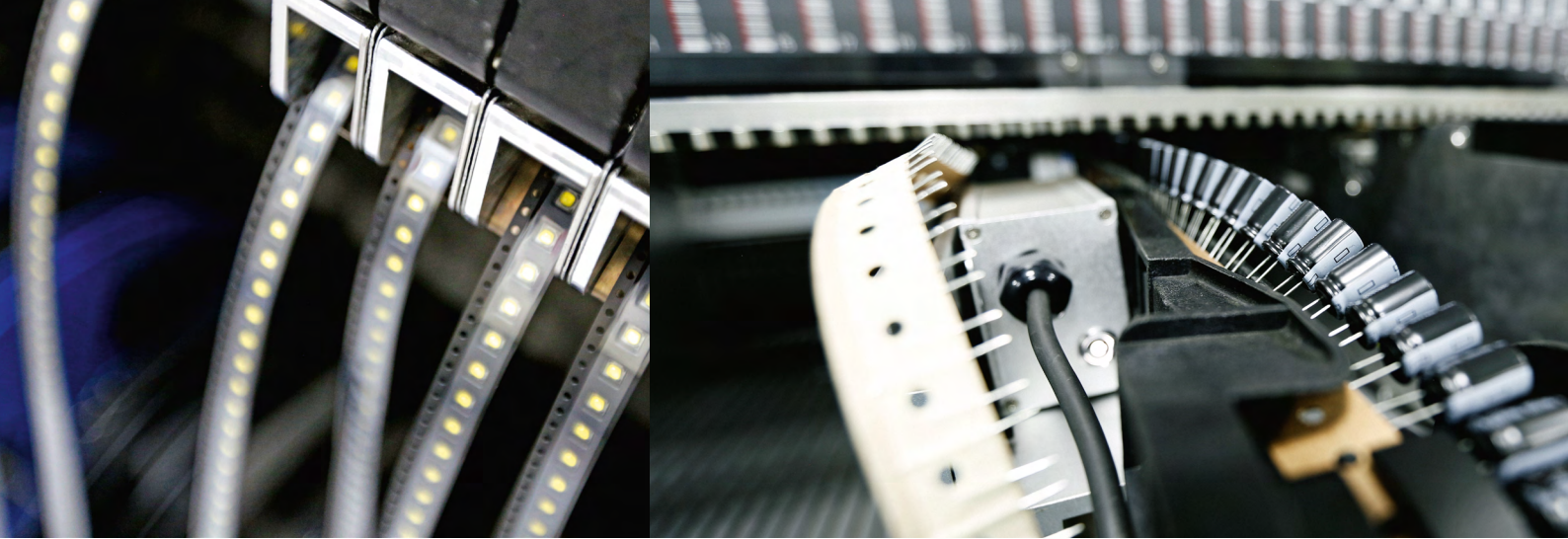

SIPLACE SX

UNBEATABLE FLEXIBILITY

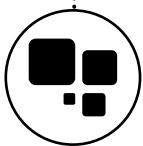

THE SIPLACE SX ADAPTS TO YOUR NEEDS

The SIPLACE SX is the world's leading placement platform for high-mix electronics production. Its flexibility begins with its huge component spectrum that is covered by three improved placement heads: CP20, CPP, and TWIN. It also offers many feeder and conveyor options. Even odd-shaped components can be supplied with exceptional reliability. Smaller boards with sizes of up to 450 mm by 260 mm can be moved with the efficient dual conveyor, and with the optional Smart Transport Module you can process boards that are up to 1,525 mm by 560 mm large.

OSC Package

Where others give up, the SIPLACE SX pushes the envelope with its OSC Package. The enhanced component diversity minimizes manual labor, and the machine's integrated process controls maximize your yield.

Third-Party Feeder

Open interfaces permit the use of a wide range of feeders – also from third-party suppliers.

3D images

The SIPLACE SX generates 3D images by combining two offset images taken by the high-resolution component camera. In this way, even damaged THT pins can be reliably detected. It also performs targeted on-board checks of highly critical areas for correct solder pads, missing components under shields, and correct positioning.

Snap-in detection

During the assembly process, the SIPLACE SX continuously checks the vertical position of components to ensure their correct placement.

Placement force

The SIPLACE SX features total placement force control from touchless placement and 0.5 N to 100 N, from the placement of sensitive LEDs to that of robust connectors.

Acceleration

No unnecessary slow-downs: The SIPLACE SX further improves your productivity by automatically determining the best travel speeds for OSCs.



SIPLACE SX SIMPLY SMART

FEWER OPERATOR ASSISTS, MORE UTILIZATION

The latest generation of the SIPLACE SX features a whole series of intelligent functions that relieve your staff from many manual adjustments or time-consuming assists and turn them into what we call 'smart operators'.

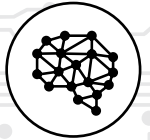

Nozzle Unique ID

No more errors caused by wrong nozzles. The SIPLACE SX recognizes the nozzle ID and reliably selects the right nozzle from the randomly filled magazine with up to 320 nozzles.

Nozzle management

The SIPLACE SX regularly analyzes each nozzle's condition, cleans them automatically, and discards damaged nozzles. SmartNozzle with RFID tag enable the tracking of every single process step of every single nozzle.

Feeder pitch

After each new setup, production job, feeder change or splice, the SIPLACE SX automatically determines the correct pitch setting for 8-mm tapes.

Smart operator guidance

If you have to deal with insufficiently described components, new fiducials or doubts regarding the correct placement height, the SIPLACE SX provides wizards that make it easy to enter and/or verify information directly at the machine or remotely for faster production starts.

Predictive maintenance

Sensors monitor the SIPLACE SX's condition and support predictive maintenance concepts.

ENTERPRISE LEVEL



FACTORY LEVEL



LINE LEVEL



MACHINE LEVEL



Digital Backbone / MES

Open interfaces

The SIPLACE SX produces not only electronic modules, but lots of valuable status and process data.

Open interfaces like WORKS Operator Information Broker, IPC-CFX or IPC-HERMES-9852 provide access to this data and integrate the SIPLACE SX into workflows, MES, traceability and cloud solutions for the intelligent factory from ASMP or from other machine manufacturers.

CAPACITY ON DEMAND PERFORMANCE WHERE IT'S NEEDED

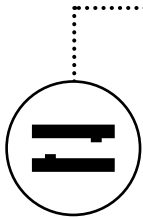

THE UNIQUE INTERCHANGEABLE GANTRIES OF THE SIPLACE SX DELIVER SCALABILITY AND A NEW LEVEL OF FLEXIBILITY.

Free yourself from the bonds of rigid line concepts and capacities.

Internal and external customers are becoming ever more demanding and set ever tighter deadlines. Sales forecasts for a product are often wrong, both upward and downward, resulting in wrongly configured lines with excess capacities or bottlenecks.

The SIPLACE SX provides an entirely new solution for volatile markets. Its interchangeable gantries can be installed or removed in a few minutes. The resulting flexibility allows you to quickly increase the capacity of a line by adding more gantries or to move gantries from one line to another to alleviate capacity bottlenecks.

The result: your production “breathes”, and your lines adapt their capacities to the demand.

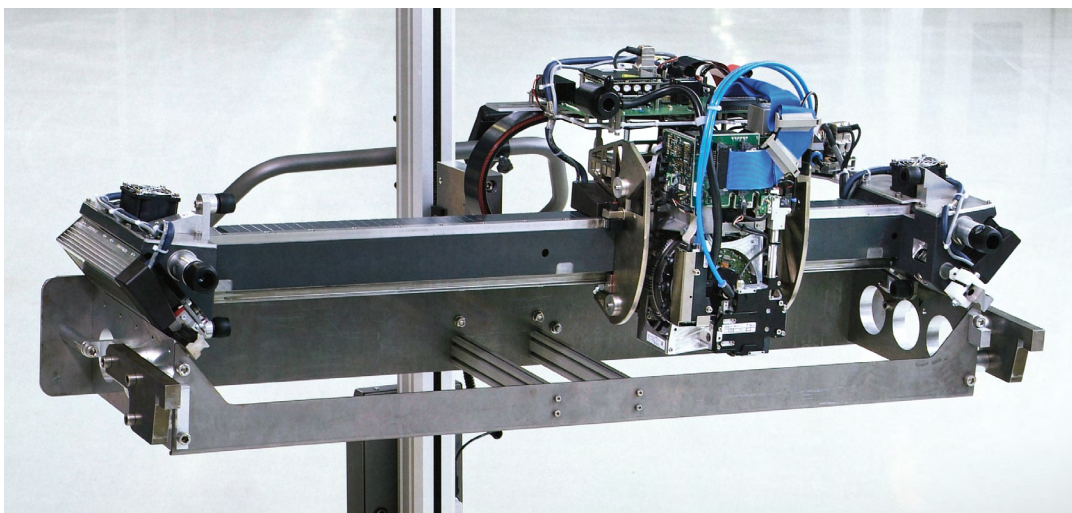
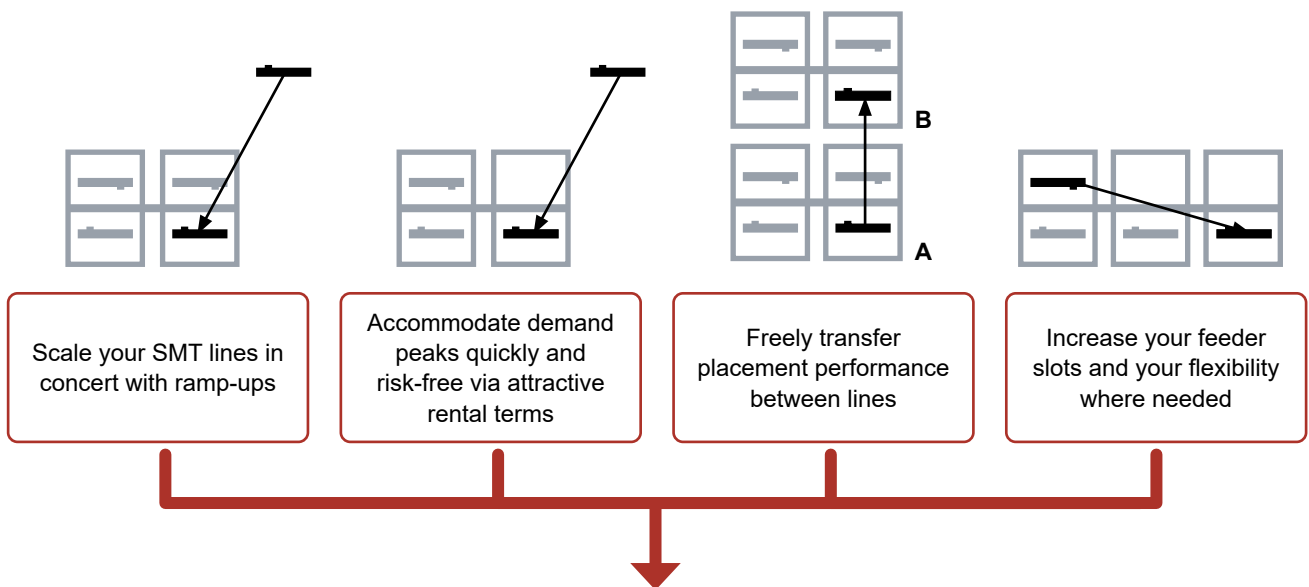

SIPLACE SX interchangeable gantries

Capacity on demand by
fastest gantry exchange

SIPLACE SX TECHNICAL DATA

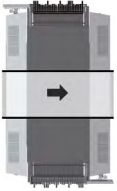
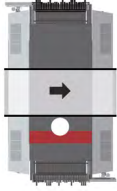
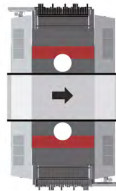
SIPLACE SX+	SIPLACE SX1	SIPLACE SX2
		
Added feeder capacity	Flexible production	High-speed production

Technical data*	SIPLACE SX1	SIPLACE SX2
Placement speed**	43,000 cph	86,500 cph
Placement speed (IPC)	33,000 cph	66,000 cph
Feeder capacity	120 × 8-mm slots	
Component spectrum	0201 (metric) to 200 mm × 110 mm × 50 mm	
Board size	50 mm × 50 mm to 1,525 mm × 560 mm	
Machine dimensions (L x W x H)	1.5 m × 2.4 m × 1.6 m	
Placement heads	Placement Head CP20P2, Placement Head CPP, Placement Head TWIN	
Placement accuracy	22 µm @ 3 σ (with Placement Head TWIN)	
Conveyors	Single-track conveyor, flexible dual-track conveyor	

Sample lines



	Placement	Speed**	Feeders	Length
SX2	CP20P2/CP20P2 (low)	66,000 cph	120	1.5 m
SX2	TWIN/CP20P2 (high)	27,000 cph	90	1.5 m
OEM line (SIPLACE SX2 + SIPLACE SX2 + SIPLACE WPC***)		93,000 cph	210	3 m



	Placement	Speed**	Feeders	Length
SX2	CP20P2/CP20P2	86,500 cph	120	1.5 m
SX1	CPP (low)	23,000 cph	120	1.5 m
SX2	TWIN/CP20P2 (high)	27,000 cph	90	1.5 m
Automotive line (SIPLACE SX2 + SIPLACE SX1 + SIPLACE SX2 + SIPLACE WPC)		136,500 cph	330	4.5 m



	Placement	Speed**	Feeders	Length
SX2	CP20P2/CP20P2 (low)	66,000 cph	120	1.5 m
SX1	CPP (high)	21,500 cph	120	1.5 m
SX1	TWIN	5,500 cph	90	1.5 m
EMS line (SIPLACE SX2 + SIPLACE SX1 + SIPLACE SX1 + SIPLACE WPC)		93,000 cph	330	4.5 m

* Performing professional maintenance in the scope and intervals recommended by ASMPT ensures that your SIPLACE equipment will deliver the specified performance and accuracy across its entire life cycle. Our maintenance contracts make this job even easier for you.

** SIPLACE benchmark

*** SIPLACE Waffle Pack Changer

ASMPT Remote Demo



A product presentation by ASMPT experts: online, free of charge, customized.
Make your SMT production even more productive, efficient, and successful!

REGISTER
NOW! >>



[smt.asmpt.com/en/
competence-network/
asmpt-remote-demo/](https://smt.asmpt.com/en/competence-network/asmpt-remote-demo/)

ASMPT

ASMPT GmbH & Co. KG

Rupert-Mayer-Strasse 48 | 81379 Munich | Germany | Phone: +49 89 20800-22000 | Email: smt-solutions.de@asmpt.com



ASMPT SMT Solutions
Website

smt.asmpt.com



ASMPT
Website

asmpt.com



ASMPT SMT Solutions
LinkedIn

[www.linkedin.com/
company/
asmpt-smt-solutions/](https://www.linkedin.com/company/asmpt-smt-solutions/)



ASMPT SMT Solutions
Facebook

[www.facebook.com/
ASMPSTSolutions](https://www.facebook.com/ASMPSTSolutions)



ASMPT SMT Solutions
YouTube

[www.youtube.com/c/
ASMPSTSolutions](https://www.youtube.com/c/ASMPSTSolutions)

Edition 6/08-2024 | All rights reserved. | Order No.: A22-ASMPT-A311-EN | Printed in Germany | © ASMPT GmbH & Co. KG

All information and illustrations in this brochure are provided "as is" and without any warranties of any kind, whether expressed or implied, including but not limited to, implied warranties of satisfactory quality, fitness for a particular purpose and/or correctness.

The contents of this brochure are for general information purposes only, do not constitute advice, and are subject to change without notice. ASMPT therefore makes no warranties or representations regarding the use of the content, details, specifications or information contained in this brochure in terms of their correctness, accuracy, adequacy, usefulness, timeliness, reliability or otherwise, in each case to the fullest extent permitted by law. Please contact ASMPT for the most current information. Any specific performance features and/or capabilities will only be binding if contractually agreed upon.

All product names are brands or trademarks of ASMPT or other suppliers. Unauthorised use by third parties may violate the rights of their owners.